

## Margaret - Margaret collection

design Cesare Arosio



\_Padded chair with wooden handle, covered with leather, velvet or fabric.

The long, narrow legs intersect with the angular structure, creating harmonious details. The main and distinctive element of the chair is the handle, integrated in the backrest's curves.

\_Sedia imbottita con maniglia in legno e ricoperta in pelle, velluto o tessuto.

Le lunghe gambe sottili si intersecano con la struttura angolare, creando dettagli armoniosi. L'elemento principale e distintivo di questa sedia è l'elegante maniglia, integrata nelle curve dello schienale.



\_dimensions

CA 301 EL chair - sedia -  
stuhl - chaise - Стул

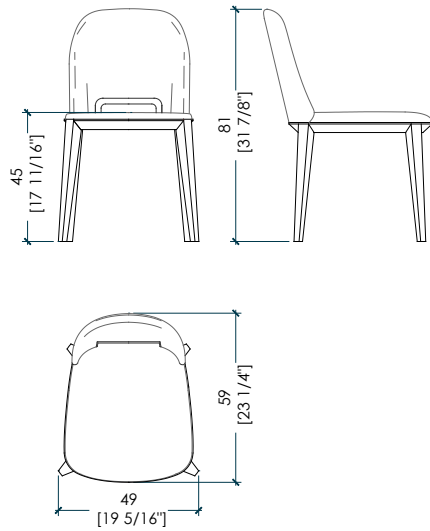

-Dimensions in centimeters and inches.  
The right to discontinue and make changes is reserved.  
This information is based on the latest product information available at the time of printing.

\_materials & finishes for structure



Natural Ash

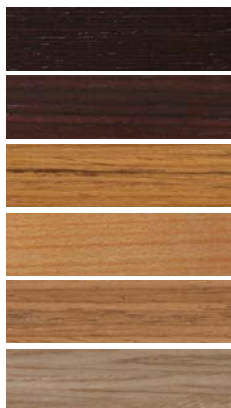

dyed in all wood colours



Brushed mat lacquered



Available in all  
RAL / NCS colours



Lacca Sabbia



Available in all  
Lacca 61 colours

\_The finishes shown are indicative and refer to the entire production range.  
Laurameroni reserves the right to modify the range without warning.

\_materials & finishes of the seat covering

nubuck leathers



Nubuck 2110  
Category A



Nubuck 2133  
Category A



Nubuck 2115  
Category A



Nubuck 2118  
Category A

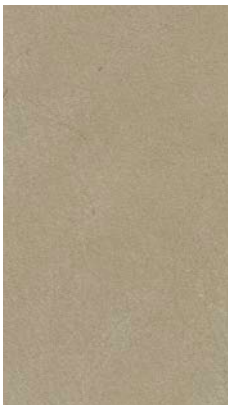

Nubuck 2101  
Category A



Nubuck 2105  
Category A



Nubuck 2102  
Category A



Nubuck 2132  
Category A



Nubuck 2103  
Category A



Nubuck 2104  
Category A

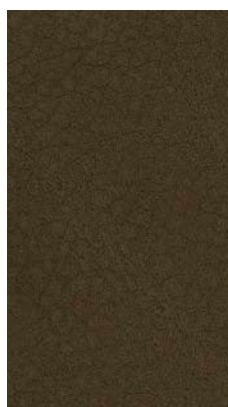

Nubuck 2116  
Category A



Nubuck 2119  
Category A

\_The finishes shown are indicative and refer to the entire production range.  
Laurameroni reserves the right to modify the range without warning.

\_materials & finishes of the seat covering

nubuck leathers



Nubuck 2125  
Category A



Nubuck 2135  
Category A



Nubuck 2109  
Category A

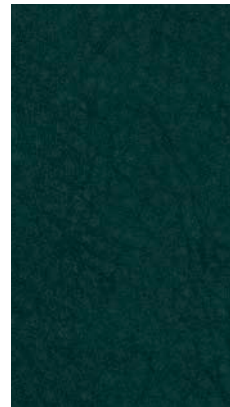

Nubuck 2106  
Category A



Nubuck 2136  
Category A

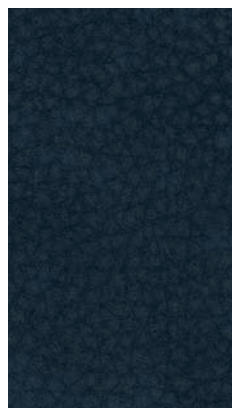

Nubuck 2108  
Category A



Nubuck 2137  
Category A



Nubuck 2134  
Category A



Nubuck 2120  
Category A

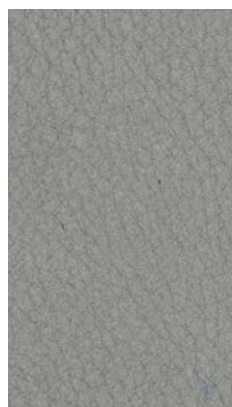

Nubuck 2130  
Category A



Nubuck 2107  
Category A

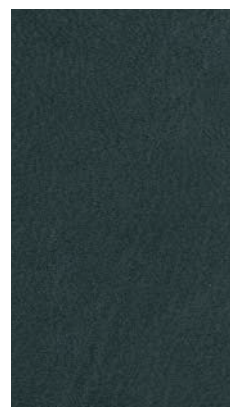

Nubuck 2117  
Category A

\_The finishes shown are indicative and refer to the entire production range.  
Laurameroni reserves the right to modify the range without warning.

\_materials & finishes of the seat covering

nubuck leathers

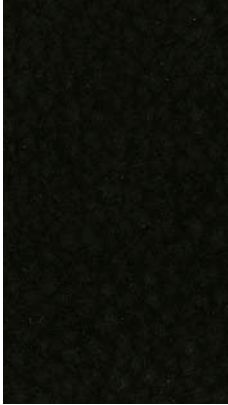

Nubuck 2114  
Category A



Nubuck 2138  
Category A

\_The finishes shown are indicative and refer to the entire production range.  
Laurameroni reserves the right to modify the range without warning.

\_materials & finishes of the seat covering

montana leathers



Montana 1302  
Category B



Montana 1304  
Category B



Montana 1305  
Category B



Montana 1303  
Category B



Montana 1301  
Category B



Montana 1306  
Category B

\_The finishes shown are indicative and refer to the entire production range.  
Laurameroni reserves the right to modify the range without warning.

\_materials & finishes of the seat covering

savana leathers



Savana 1008  
Category B

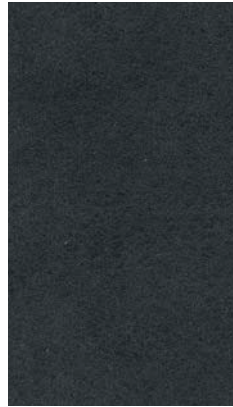

Savana 1007  
Category B



Savana 1003  
Category B

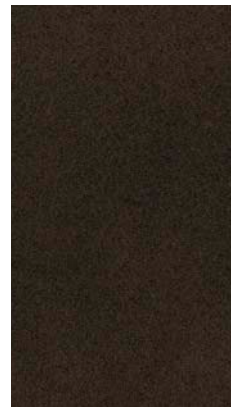

Savana 1004  
Category B



Savana 1012  
Category B

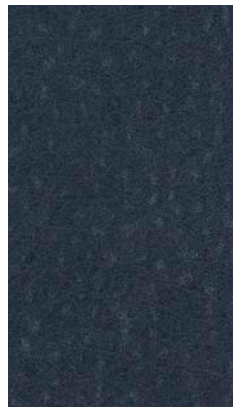

Savana 1009  
Category B



Savana 1002  
Category B



Savana 1006  
Category B



Savana 1001  
Category B



Savana 1005  
Category B

\_The finishes shown are indicative and refer to the entire production range.  
Laurameroni reserves the right to modify the range without warning.



\_materials & finishes of the seat covering

cloud leathers



Cloud 4109  
Category C



Cloud 3403  
Category C



Cloud 6048  
Category C



Cloud 1015  
Category C

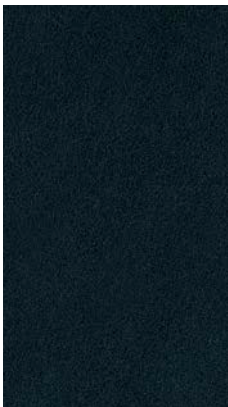

Cloud 779  
Category C

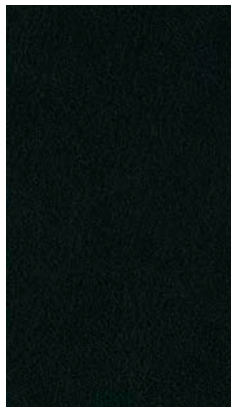

Cloud 6099  
Category C

\_The finishes shown are indicative and refer to the entire production range.  
Laurameroni reserves the right to modify the range without warning.

materials & finishes of the seat covering

"shiny" velvet



Velvet 407



Velvet 417



Velvet 403



Velvet 412



Velvet 438



Velvet 418



Velvet 405



Velvet 401



Velvet 431



Velvet 429



Velvet 409



Velvet 404

The finishes shown are indicative and refer to the entire production range.  
Laurameroni reserves the right to modify the range without warning.

\_materials & finishes of the seat covering  
"shiny velvet"



Velvet 414



Velvet 424



Velvet 413



Velvet 437



Velvet 457



Velvet 477



Velvet 487



Swing 415

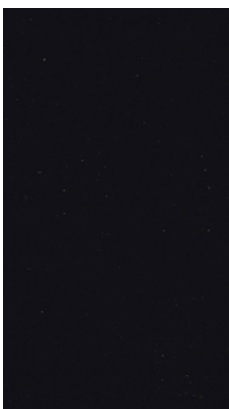

Velvet 406

\_The finishes shown are indicative and refer to the entire production range.  
Laurameroni reserves the right to modify the range without warning.

\_materials & finishes of the seat covering

"mat" velvet



Velvet 01



Velvet 02



Velvet 23



Velvet 06



Velvet 07



Velvet 29

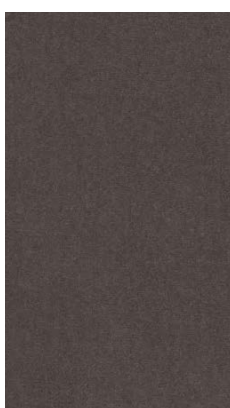

Velvet 28



Velvet 2003

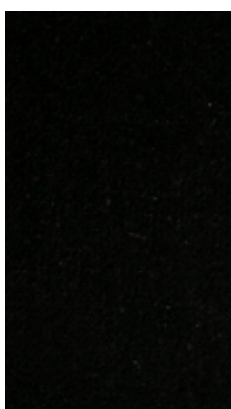

Velvet 26



Velvet 1406



Velvet 1402



Velvet 20

\_The finishes shown are indicative and refer to the entire production range.  
Laurameroni reserves the right to modify the range without warning.

\_materials & finishes of the seat covering

"mat" velvet



Velvet 2004

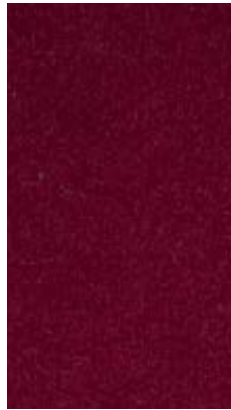

Velvet 17



Velvet 2007



Velvet 2008



Velvet 1405

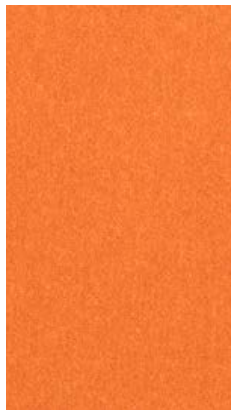

Velvet 13



Velvet 34



Velvet 1403



Velvet 1401

\_The finishes shown are indicative and refer to the entire production range.  
Laurameroni reserves the right to modify the range without warning.

\_maintenance

#### **-WOOD**

Wood is a high-quality natural product. To maintain the natural character of wood and to protect surfaces from mechanical and chemical wear, veneered surfaces are coated with a high quality transparent paint. For cleaning and care, do not use acids or alkali-based cleaners, agents with bleaching additive, scouring powder, steel wool, pot scourers or similar. Anything hot or damp will cause damage to the surface. Remove soiling and liquids immediately. Use a dry soft cloth for cleaning, eventually add a little neutral cleaning agent to the water. The cloth must be only slightly damp, to prevent discolouration or swelling of the surface. It is then essential to rub the surfaces dry, so that there is no residual moisture.

#### **-LEATHER**

Leather is a natural product. It is individual, unmistakable and very durable. Natural unevenness, softness and minimal colouring which allows the material to breathe are the features of the best quality leathers. For maintenance and cleaning do not use acids or alkali-based cleaners. Never use stain remover, shoe cream, solvents, floor wax, cosmetics or other aggressive cleaning agents. Do not use scouring agents, steel wool, pot cleaners or similar. We recommend you do not expose the product to strong heat, as this can change its appearance. Please protect the product from abrasion, moisture and other factors so that the surface is not damaged beyond repair. Dust the leather surface regularly with a soft cloth. Use the blunt nozzle of a vacuum cleaner to remove crumbs and sand.

If you use wrong products, the finish of the leather may be damaged seriously; damage appears as time passes, after several cleaning operations. Attention: nubuck grain leather as well as leathers finished with aniline cannot be cleaned at all, if not with a simple dry and soft cloth. Any product could damage irrecoverably the leather!

Nubuck  
European bovine hide, chrome tanned, aniline dyed. Nubuck natural grain.

Pixel  
European bovine hide, chrome tanned, barrel dyed with aniline. Silkscreen-WR.

Tosca  
European origin, chrome tanned, drum dyed, printed and finished to obtain a lightening effect.

Swing  
European bovine hide, chrome tanned, aniline dyed. Top-grain leather, smooth matt surface, silky touch.

Skin  
European bovine hide, dry vacuum, aniline dyed. Natural look, full hand, silky touch.

\_maintenance

## VELVET

Velvet is a woven pile fabric whose pile is less than 3 mm high. Velvet can be made from both natural and synthetic fibres. Depending on the material used to make it, its density and its pile length, velvet can be very fine, soft and flowing or tougher and firmer.

Our velvet fabrics have to be dry-cleaned.

Dust and loose dirt should be removed from velvet regularly by vacuuming it using a special upholstery nozzle (soft bristles). The upholstery nozzle must not have a ridge or sharp edges, as these could damage the fabric. Please also brush your velvet furniture regularly using a soft brush (such as a clothes brush), going with the grain. If necessary, you can also wipe your furniture in the direction of the grain with a damp chamois (light pressure) or use mild cleaning foam for a deeper clean. Please test it first.

Deep cleaning should only be performed by an expert upholstery cleaner. Depending on how much wear the furniture is subject to and the colour of the velvet, we recommend professional deep cleaning every four to five years.

You should hire a specialist to remove stains. If you want to try to remove the stain yourself first, proceed as follows:

Cleaning products must be tested first to ensure they are suitable. Make sure you choose a pH-neutral product. Acidic products damage cotton and cellulose fabrics. We recommend using special upholstery cleaning products to remove stains and clean furniture effectively.

Remove dust first, then test the colour fastness and changes to the surface of the upholstery fabric on an inconspicuous area by rubbing it with a clean, soft, white cloth dipped in the cleaning or stain removal product.

In some cases, pressure, heat and moisture can cause pressure marks on velvet, which may be light or heavy. This is typical of the product type and not a sign of inferior quality. In our experience, it is not always possible to remove sitting marks by treating the fabric, e.g. steaming and brushing it.

To some degree, sitting marks are therefore typical of all woven pile fabrics. The best way to reduce them is to clean the fabric regularly and occasionally brush the pile in every direction.

Please ensure that no hot-water bottles, electric blankets, etc. are placed on the fabric. The combination of heat and pressure can permanently change the surface of the fabric.

We recommend you do not expose the product to strong heat, as this can change its appearance.

## SHINY VELVETS

100% Polyester



BEDIF  
FEREN  
TBEUN  
IQUE.

LAURAMERONI s.r.l.  
22040 Alzate Brianza (Como)  
Via Manzoni, 2784  
T +39 031 761450  
info@laurameroni.com  
www.laurameroni.com