

## Elemento - Moving collection

design Paolo Nicolò Rusolen



Table with modules in marble or wood and openable glass cases, available in different lengths (multiples of 15). Legs in extra-clear glass.

Modules available in marble and in all the woods of the collection.

Tavolo con moduli in marmo o legno e teche apribili in cristallo, disponibile in diverse lunghezze (multipli di 15). Gambe in cristallo extrachiaro.

Moduli disponibili in marmo e in tutti i legni della collezione.



## Elemento - Moving collection

design Paolo Nicolò Rusolen



The Elemento project stems from the idea of creating light-looking products, with an effect of "full and empty" accentuated by the crystal base.

The minute workmanship at the points of contact between the two materials gives an appearance of fusion, for a precious and exclusive effect.

Il progetto Elemento nasce dall'idea di creare prodotti dall'aspetto leggero, con un effetto di "pieni e vuoti" accentuato dalla base in cristallo.

La minuta lavorazione nei punti di contatto tra i due materiali dona un'apparenza di fusione, per un effetto prezioso ed esclusivo.

\_dimensions

PR 51 rectangular table - tavolo rettangolare -  
rechteckiger tisch - table rectangulaire - Прямоугольный стол

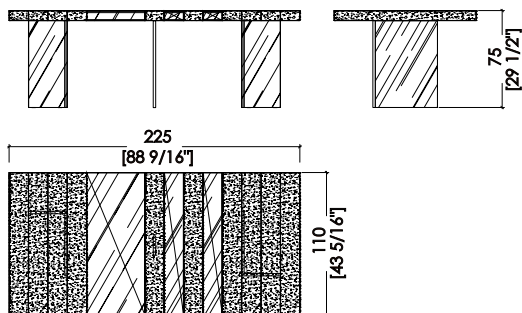

PR 52 rectangular table - tavolo rettangolare -  
rechteckiger tisch - table rectangulaire - Прямоугольный стол

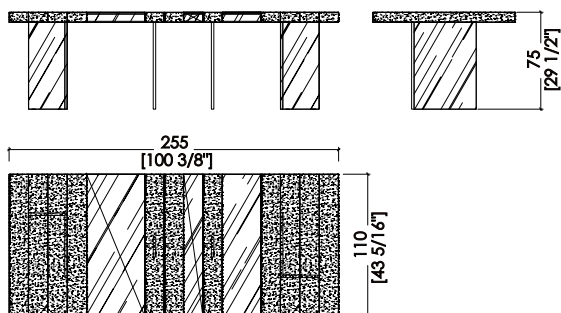

PR 53 rectangular table - tavolo rettangolare -  
rechteckiger tisch - table rectangulaire - Прямоугольный стол

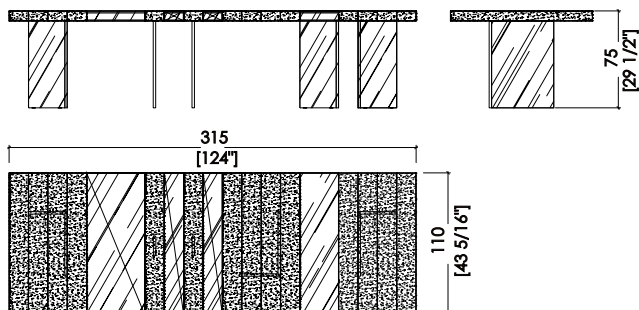

Available in special dimensions.

- Dimensions in centimeters and inches.

The right to discontinue and make changes is reserved.

This information is based on the latest product information available at the time of printing.

\_assembly instructions

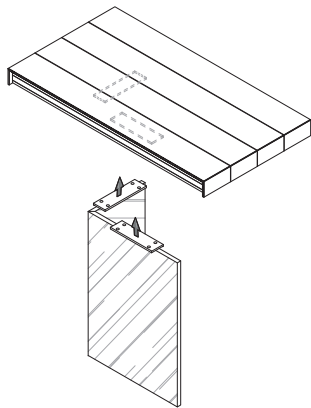

**1** Place the top on the leg by matching the slot with the hardware and screw it.

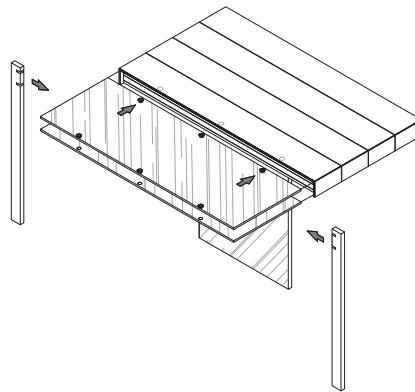

**2** Insert the glass into its special slot with the help of the special supports.

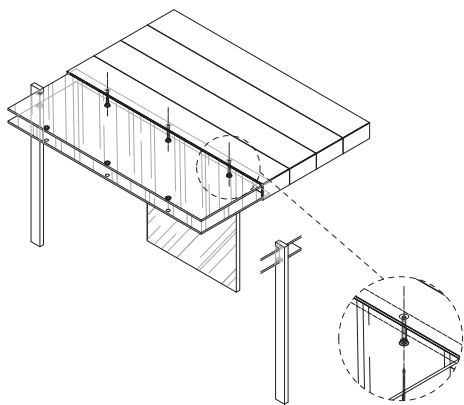

**3** Use the appropriate hardware to fix the glass tops to the marble.

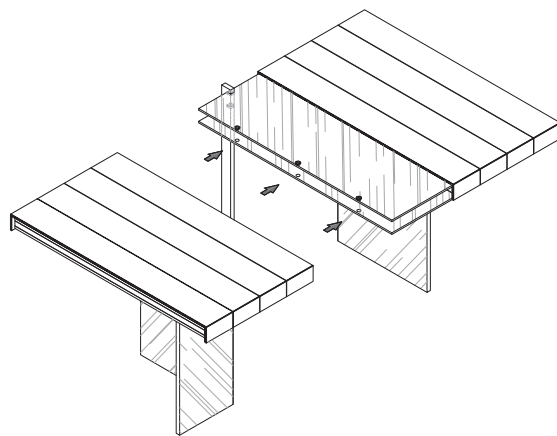

**4** After having mounted the second leg, as in step 1, bring the second glass surface closer by matching the slot with the glasses.

\_assembly instructions

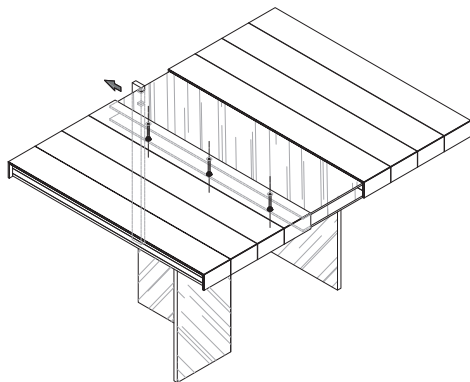

**5** Use the appropriate hardware to fix the glass tops to the marble. Remove the special supports that held the glasses.

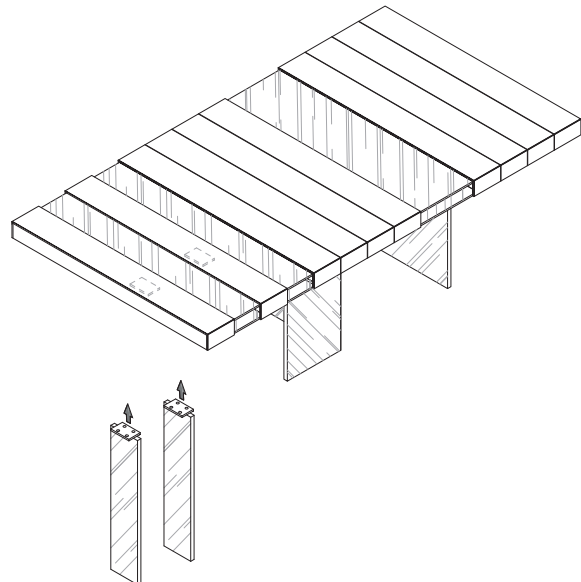

**6** Fix the legs under the top by matching the housing with the hardware.

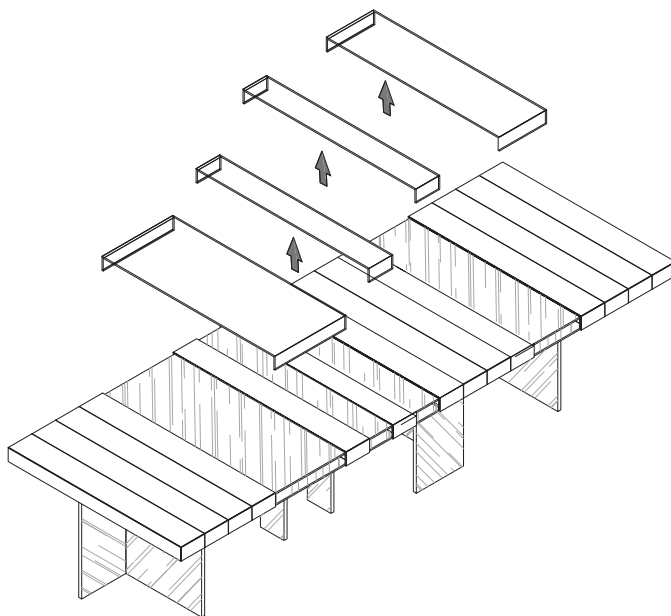

**7** Place the display cases in the appropriate spaces.

\_materials & finishes

plain woods

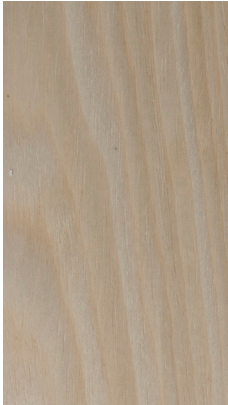

Maple



Oak



Teak



Zebrano



Canaletto Walnut

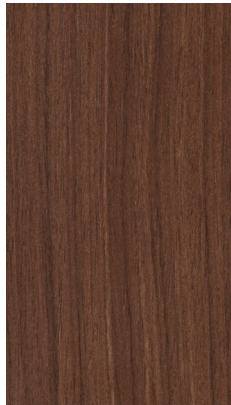

Dyed Canaletto walnut

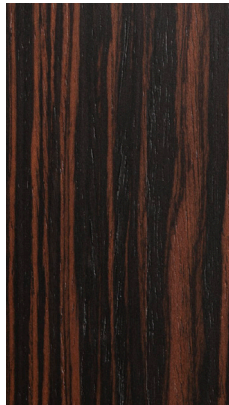

Ebony



Termocotto Oak

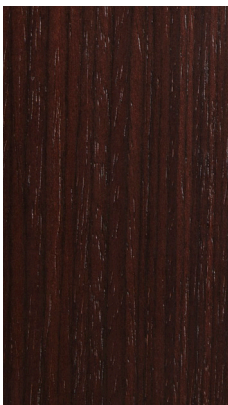

Rosewood



Wenge



Mahogany

\_The finishes shown are indicative and refer to the entire production range.  
Laurameroni reserves the right to modify the range without warning.

\_materials & finishes

dyed woods



Titanium AL1105



Grey AL1106



Sand AL1851



Black AL1853

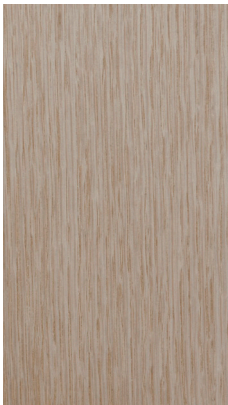

Aniline dyed



Available in all  
RAL / NCS colours

\_The finishes shown are indicative and refer to the entire production range.  
Laurameroni reserves the right to modify the range without warning.

\_materials & finishes

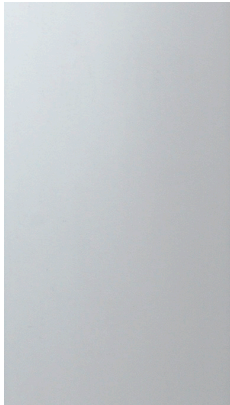

Ultra-light crystal

\_materials & finishes

marbles

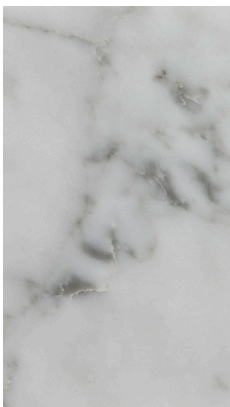

Bianco Carrara

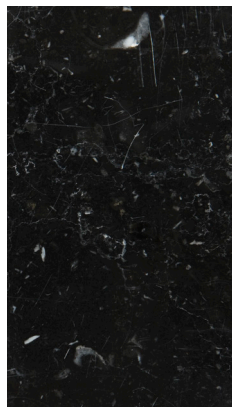

Nero Marquina

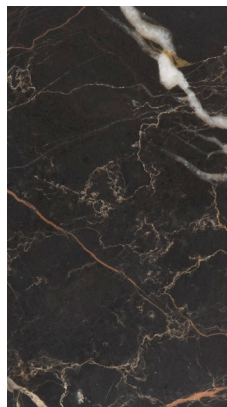

New Port Laurent levigato

\_The finishes shown are indicative and refer to the entire production range.  
Laurameroni reserves the right to modify the range without warning.



\_materials & finishes

special woods

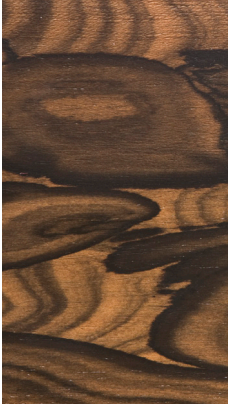

Ziricote



Stone Oak Carbone

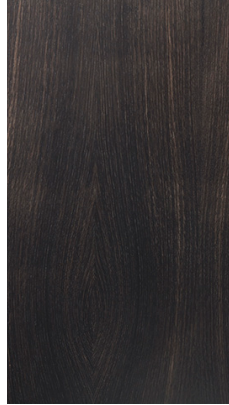

Stone Oak Tabacco

\_The finishes shown are indicative and refer to the entire production range.  
Laurameroni reserves the right to modify the range without warning.

\_maintenance

**\_MARBLE**

Natural stones are easily damaged by acids, fats and oils. These liquids tend to penetrate natural stone and leave dark, light or opaque stains that can no longer be removed.

Do not use acid cleaners, solvents or alkalis. Do not use abrasive agents, steel wool, pot cleaners, glass cleaners, aggressive solvents, dyes, bleach or the like. Anything hot or humid can cause surface damage.

For the cleaning and care, protect the product from abrasion, moisture and other external influences to prevent long-term destruction of the surface. Dust the natural stone regularly with a soft, lint-free cloth. Remove dirt and liquids immediately using only neutral detergents.

**\_MARMO**

Le pietre naturali sono facilmente danneggiabili da acidi, grassi ed oli. Questi liquidi tendono a penetrare nella pietra naturale e lasciare macchie scure, chiare od opache che non possono più essere rimosse.

Non utilizzare detergenti acidi, solventi o alcali. Non usare agenti abrasivi, lana d'acciaio, detergenti per pentole, detergenti per vetri, solventi aggressivi, coloranti, candeggina o simili. Qualsiasi cosa calda o umida può causare danni alla superficie.

Per la pulizia e la cura, proteggere il prodotto dall'abrasione, dall'umidità e da altre influenze esterne per prevenire la distruzione a lungo termine della superficie.

Spolverare la pietra naturale regolarmente con un panno morbido e privo di lanugine. Rimuovere immediatamente sporco e liquidi utilizzando solo detergenti neutri.

\_maintenance

**WOOD**

To maintain the natural wood features and protect them from mechanical and chemical wear, the veneered surfaces are coated with a high-quality transparent varnish. Do not use acid or alkaline detergents, agents with bleaching additives, abrasive powders, steel wool, sponges or the like. Anything hot or humid can cause surface damage. Remove dirt and liquids immediately.

For the cleaning and care, it is best to use a soft, dry cloth. If necessary, the cloth can be slightly dampened and dipped in neutral detergent thoroughly diluted in water. The cloth should only be slightly damp to avoid discoloration or swelling of the surface. Finally, it is essential to gently rub dry surfaces, so that there is no residual moisture.

**LEGNO**

Per mantenere il carattere naturale del legno e proteggerlo dall'usura meccanica e chimica, le superfici impiallacciate sono rivestite con una vernice trasparente di alta qualità.

Non usare detergenti acidi o alcalini, agenti con additivi sbiancanti, polveri abrasive, lana d'acciaio, spugne o simili. Qualsiasi cosa calda o umida può causare danni alla superficie. Rimuovere immediatamente sporco e liquidi. Per la pulizia e la cura, è preferibile utilizzare un panno morbido e asciutto. Eventualmente il panno può essere leggermente inumidito ed intinto in detergente neutro abbondantemente diluito in acqua. Il panno deve essere solo leggermente umido, per evitare scolorimenti o rigonfiamenti della superficie. È infine essenziale strofinare gentilmente le superfici asciutte, in modo che non sussista umidità residua.

**BEDIF  
FEREN  
TBEUN  
IQUE.**

LAURAMERONI s.r.l.  
22040 Alzate Brianza (Como)  
Via Manzoni, 2784  
T +39 031 761450  
info@laurameroni.com  
www.laurameroni.com