

Talento up - Talento collection

design Edoardo Colzani Design



Wooden sideboard with doors or drawers in liquid metal with Unlimited texture, tubular metal legs and design handle in burnished brass.

Available in two sizes, with structure available in wood and with a special Patina Bronzata Antica finish.

Credenza in legno con ante o cassetti in metallo liquido con texture Unlimited, gambe tubolari in metallo e maniglia di design in ottone brunito.

Disponibile in due dimensioni, con struttura disponibile in legno e con finitura speciale Patina Bronzata Antica.

_dimensions

TAL D23 low storage unit - mobile contenitore basso -
niedriges behältermöbel - meuble conteneur bas - Низкий шкаф

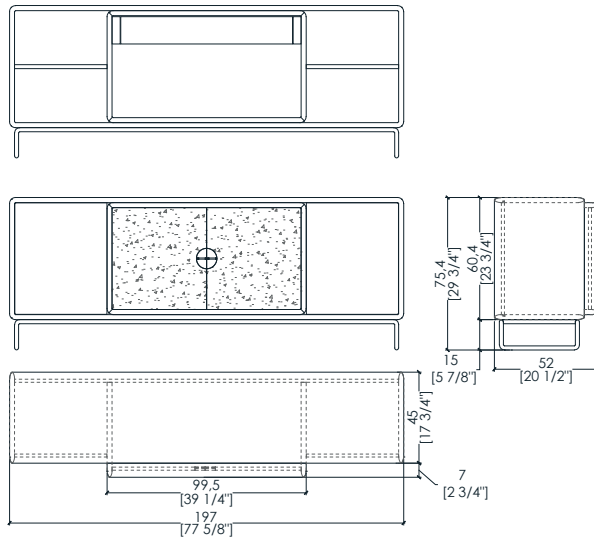

TAL C33 low storage unit - mobile contenitore basso -
niedriges behältermöbel - meuble conteneur bas - Низкий шкаф

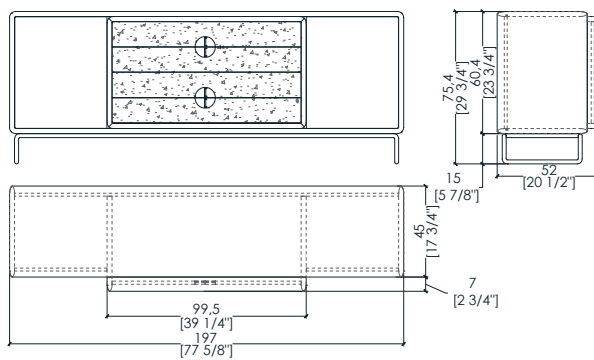

-Dimensions in centimeters and inches.

The right to discontinue and make changes is reserved.

This information is based on the latest product information available at the time of printing.

_dimensions

TAL D24 low storage unit - mobile contenitore basso -
niedriges behältermöbel - meuble conteneur bas - Низкий шкаф

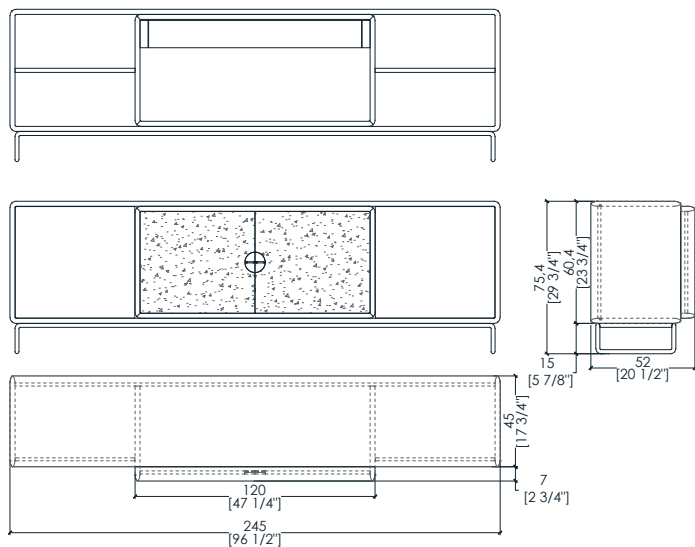

TAL C34 low storage unit - mobile contenitore basso -
niedriges behältermöbel - meuble conteneur bas - Низкий шкаф

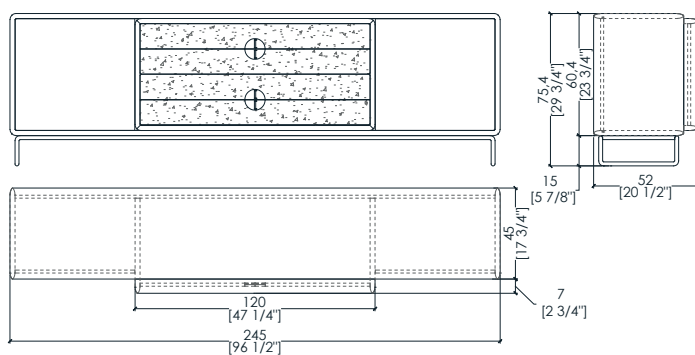

-Dimensions in centimeters and inches.

The right to discontinue and make changes is reserved.

This information is based on the latest product information available at the time of printing.

materials & finishes for the structure, the container and the interiors

plain woods



Maple



Oak



Teak



Zebrano



Canaletto Walnut



Dyed Canaletto walnut

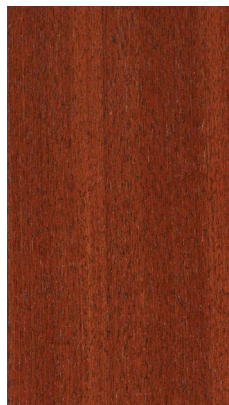

Mahogany



Ebony



Termocotto Oak



Rosewood

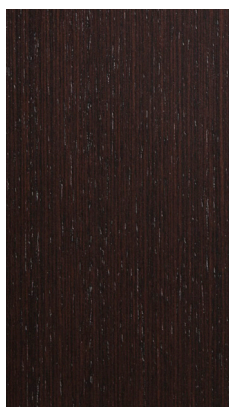

Wenge

The finishes shown are indicative and refer to the entire production range.
Laurameroni reserves the right to modify the range without warning.

_materials & finishes for the structure, the container and the interiors
dyed woods



Titanium AL1105



Grey AL1106



Sand AL1851



Black AL1853



Aniline dyed



Available in all
RAL / NCS colours

_The finishes shown are indicative and refer to the entire production range.
Laurameroni reserves the right to modify the range without warning.

_materials & finishes for the structure and the doors

lacquering

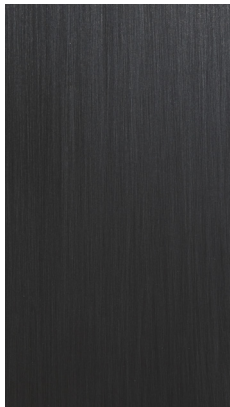

Brushed matt lacquered



Available in all
RAL / NCS colours

_materials & finishes for the doors

metallic varnishes



“Patina bronzata antica”

_The finishes shown are indicative and refer to the entire production range.
Laurameroni reserves the right to modify the range without warning.

_materials & finishes for the doors

unlimited liquid metal



Liquid Metal Bronze

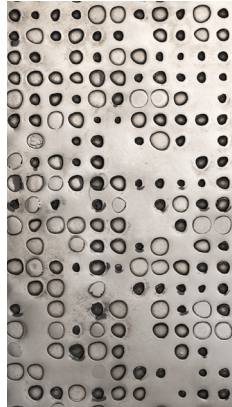

Liquid Metal Tin

_materials & finishes for the structure

metallic varnishes



Delabré metallic paint

_The finishes shown are indicative and refer to the entire production range.
Laurameroni reserves the right to modify the range without warning.

_maintenance

LIQUID METALS

To maintain the natural features of the metal and to protect the specific craftsmanship from oxidation and discoloration, the metal surfaces are coated with a high-quality transparent varnish. Do not use acid cleaners, solvents or alkalis. Do not use abrasive agents, steel wool, pot cleaners, glass cleaners, aggressive solvents, dyes, bleach or the like. Pointed or sharp objects, such as blades or knives, can cause damage to the surface. Anything hot or humid can cause surface damage.

For cleaning and care, remove light dirt with a soft cloth and a neutral household cleaning product well diluted in water. Gently clean the metal parts by hand with cold or warm water and dry immediately with a soft cloth.

METALLO LIQUIDO

Per mantenere il carattere naturale del metallo e tutelare la specifica lavorazione artigianale da ossidazione e scolorimento, le superfici metalliche sono rivestite con una vernice trasparente di alta qualità.

Non utilizzare detergenti acidi, solventi o alcali. Non usare agenti abrasivi, lana d'acciaio, detergenti per pentole, detergenti per vetri, solventi aggressivi, coloranti, candeggina o simili. Oggetti appuntiti o taglienti, come lame o coltelli, possono causare danni alla superficie. Qualsiasi cosa calda o umida può causare danni alla superficie.

Per la pulizia e la cura, rimuovere lo sporco leggero con un panno morbido ed un prodotto neutro per la pulizia della casa abbondantemente diluito in acqua.

Pulire delicatamente a mano le parti metalliche con acqua fredda o tiepida ed asciugare immediatamente con un panno morbido.

_maintenance

_WOOD

To maintain the natural wood features and protect them from mechanical and chemical wear, the veneered surfaces are coated with a high-quality transparent varnish. Do not use acid or alkaline detergents, agents with bleaching additives, abrasive powders, steel wool, sponges or the like. Anything hot or humid can cause surface damage. Remove dirt and liquids immediately.

For the cleaning and care, it is best to use a soft, dry cloth. If necessary, the cloth can be slightly dampened and dipped in neutral detergent thoroughly diluted in water. The cloth should only be slightly damp to avoid discoloration or swelling of the surface. Finally, it is essential to gently rub dry surfaces, so that there is no residual moisture.

_LEGNO

Per mantenere il carattere naturale del legno e proteggerlo dall'usura meccanica e chimica, le superfici impiallacciate sono rivestite con una vernice trasparente di alta qualità. Non usare detergenti acidi o alcalini, agenti con additivi sbiancanti, polveri abrasive, lana d'acciaio, spugne o simili. Qualsiasi cosa calda o umida può causare danni alla superficie. Rimuovere immediatamente sporco e liquidi. Per la pulizia e la cura, è preferibile utilizzare un panno morbido e asciutto. Eventualmente il panno può essere leggermente inumidito ed intinto in detergente neutro abbondantemente diluito in acqua. Il panno deve essere solo leggermente umido, per evitare scolorimenti o rigonfiamenti della superficie. È infine essenziale strofinare gentilmente le superfici asciutte, in modo che non sussista umidità residua.

_maintenance

**PAINTS, LACQUERINGS AND
SPECIAL FINISHES**

To maintain the natural wood features and protect them from mechanical and chemical wear, the veneered surfaces are coated with a high-quality transparent varnish. Do not use acid or alkaline detergents, agents with bleaching additives, abrasive powders, steel wool, sponges or the like. Anything hot or humid can cause surface damage. Remove dirt and liquids immediately.

For the cleaning and care, it is best to use a soft, dry cloth. If necessary, the cloth can be slightly dampened and dipped in neutral detergent thoroughly diluted in water. The cloth should only be slightly damp to avoid discoloration or swelling of the surface. Finally, it is essential to gently rub dry surfaces, so that there is no residual moisture.

**TINTE, LACCATURE E FINITURE
SPECIALI**

Non usare detergenti acidi o alcalini, agenti con additivi sbiancanti, polveri abrasive, lana d'acciaio, spugne o simili. Non utilizzare lucidi per mobili o solventi per la cura delle superfici verniciate. Qualsiasi cosa calda o umida può causare danni alla superficie. Oggetti appuntiti o taglienti, come lame o coltelli, possono causare danni alla superficie.

Per la pulizia e la cura, pulire regolarmente le superfici con un panno pulito, morbido e privo di lanugine per rimuovere la polvere evitando l'abrasione. Per le superfici verniciate con finitura morbida, utilizzare un panno soffice, privo di lanugine e leggermente umido. Se molto sporche, le superfici verniciate possono essere pulite con un detergente neutro privo di silicone. È infine essenziale strofinare gentilmente le superfici asciutte, in modo che non sussista umidità residua.

**BEDIF
FEREN
TBEUN
IQUE.**

LAURAMERONI s.r.l.
22040 Alzate Brianza (Como)
Via Manzoni, 2784
T +39 031 761450
info@laurameroni.com
www.laurameroni.com