

## Boiserie Onda - Graffiti collection

design Paolo Rizzato



Made to measure wood veneered board with horizontal or vertical Onda carving on the sight side, available in all woods and finishes of the collection and with integrated hinged or sliding doors.

Pannelli boiserie realizzati su misura con scolpitura Onda verticale od orizzontale su lato a vista, disponibile in tutti i legni e le finiture della collezione e in combinazione con porte battenti o scorrevoli integrate.

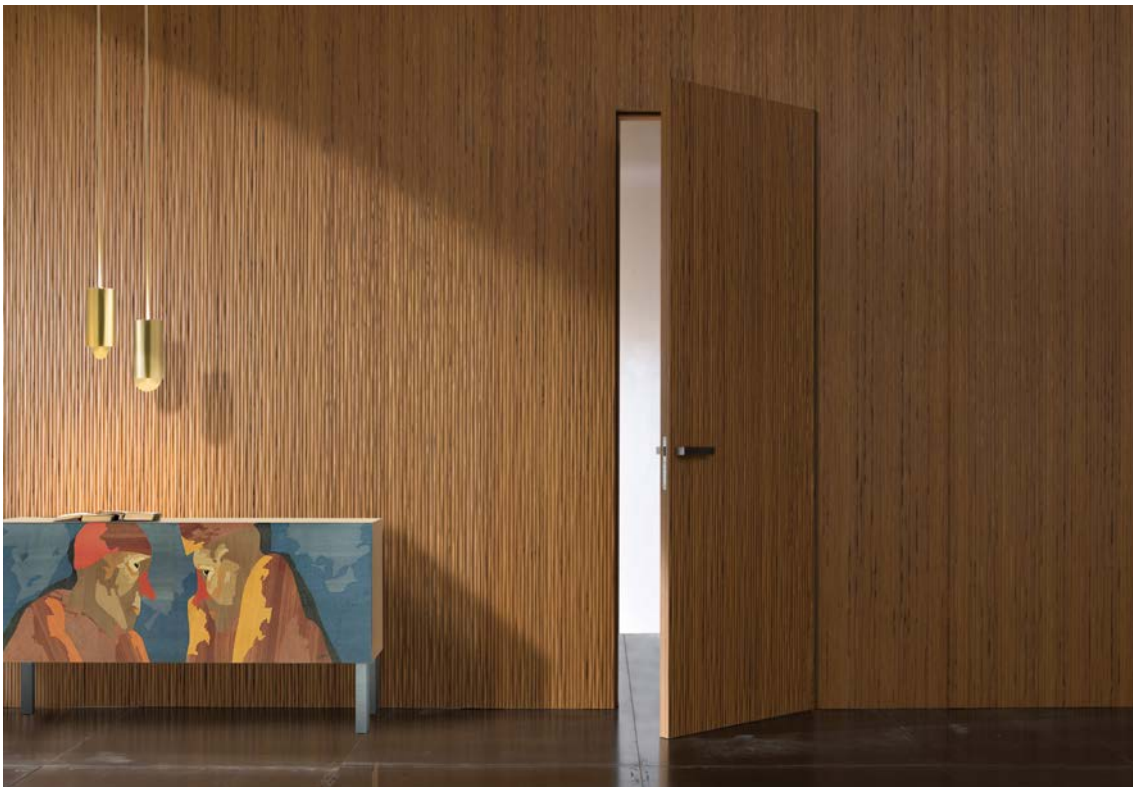

\_dimension limits

**wall panel** - pannello boiserie -  
wandpaneel - panneau boiserie - Стеновая панель

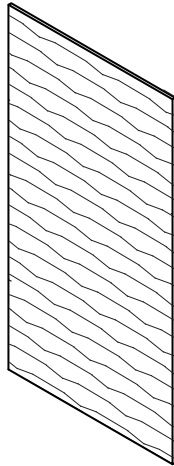

horizontal  
onda carving

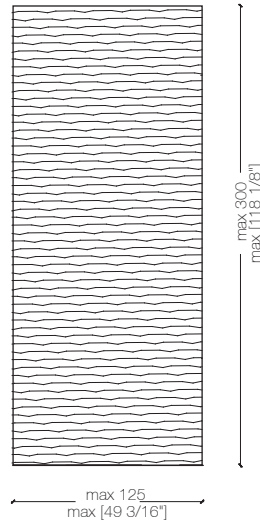

\_dimension limits

**wall panel** - pannello boiserie -  
wandpaneel - panneau boiserie - Стеновая панель

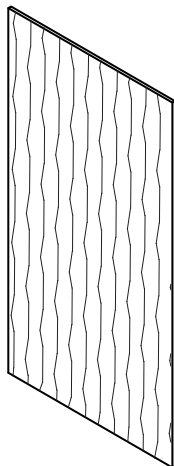

vertical  
onda carving

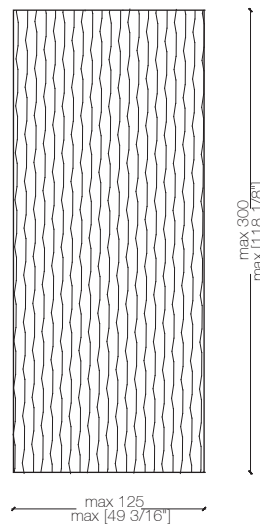

-Dimensions in centimeters and inches.  
The right to discontinue and make changes is reserved.  
This information is based on the latest product information available at the time of printing.

\_dimensions limits

**wall panel** - pannello boiserie -  
wandpaneel - panneau boiserie - Стеновая панель

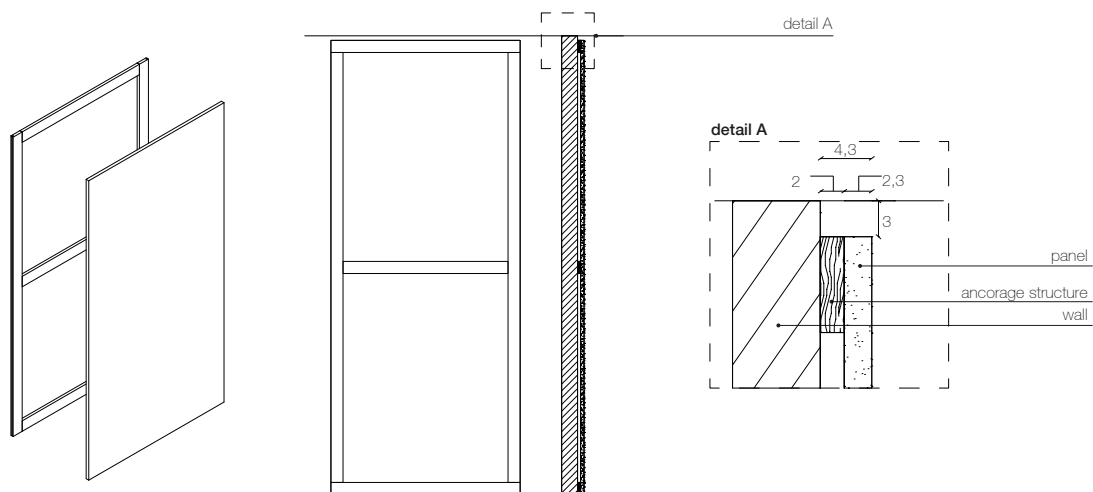

**wall panel with closing band** - pannello boiserie con fascia di chiusura -  
wandpaneel mit schlussband - panneau boiserie avec bande de fermeture  
Стеновая панель с закрывающей лентой

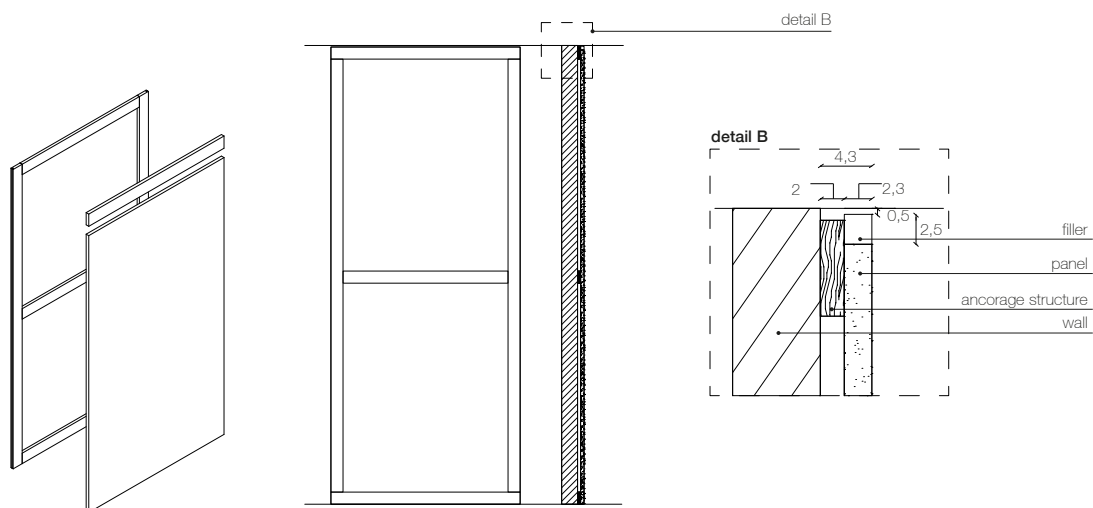

-Dimensions in centimeters and inches.  
The right to discontinue and make changes is reserved.  
This information is based on the latest product information available at the time of printing.

\_dimensions

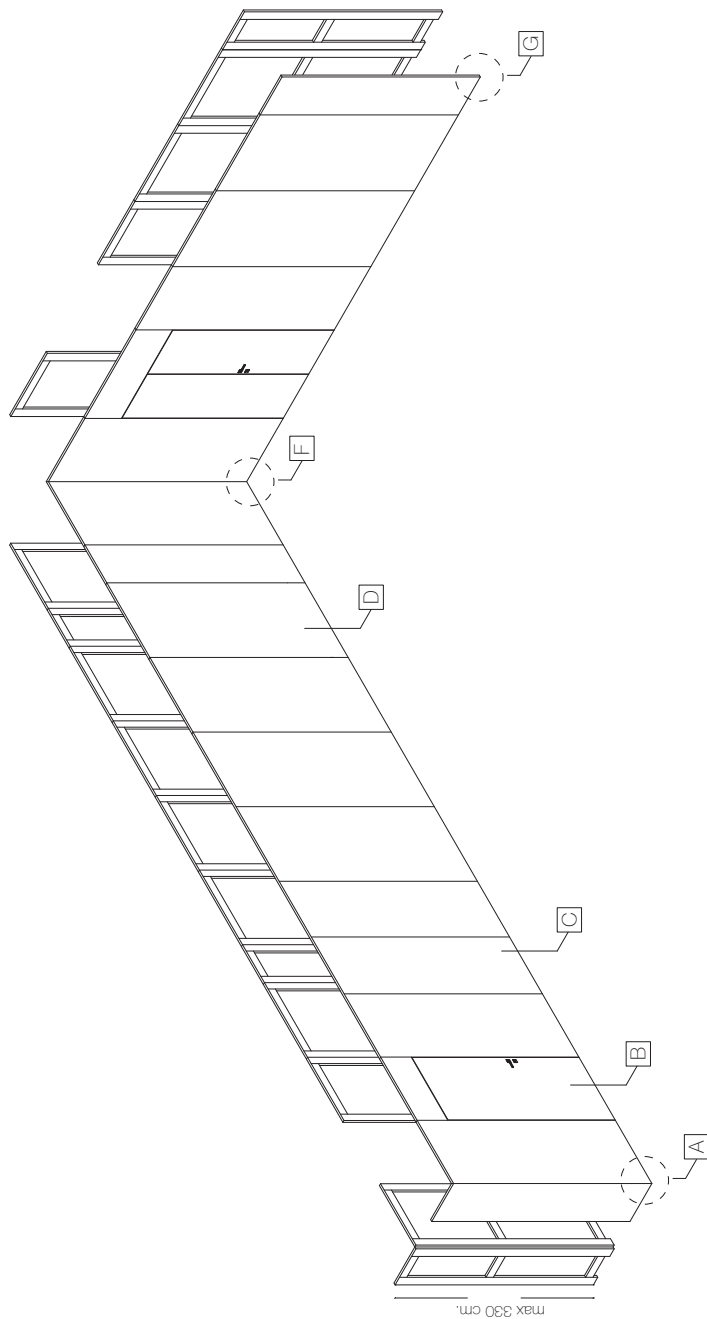

wall panel system with hinged doors - sistema boiserie con porte battenti  
wandpaneel systeem met flügelüren - système boiserie avec portes  
battantes - система стеновых панелей с распашными дверями

-Dimensions in centimeters and inches.  
The right to discontinue and make changes is reserved.  
This information is based on the latest product information available at the time of printing.

\_dimensions

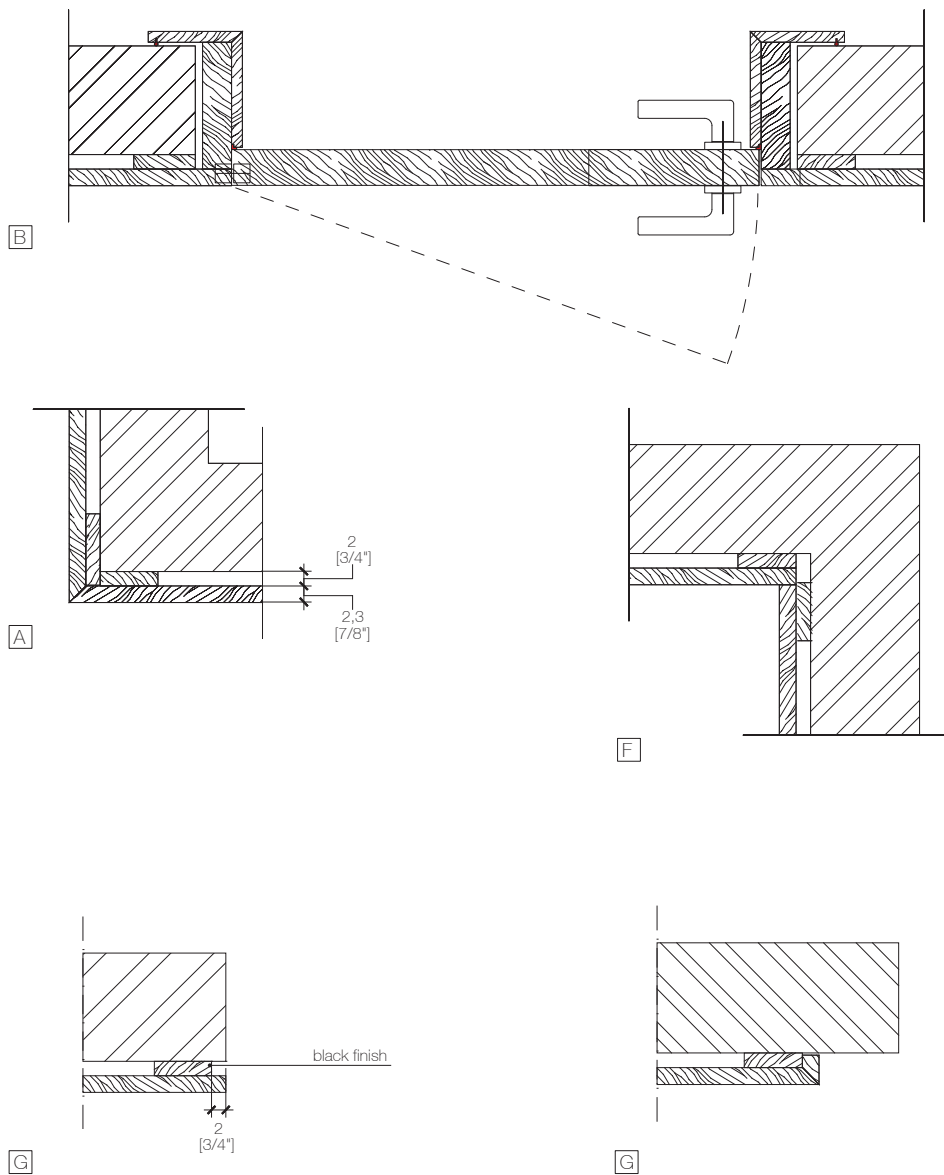

-Dimensions in centimeters and inches.  
The right to discontinue and make changes is reserved.  
This information is based on the latest product information available at the time of printing.

\_assembly instruction

wall panels

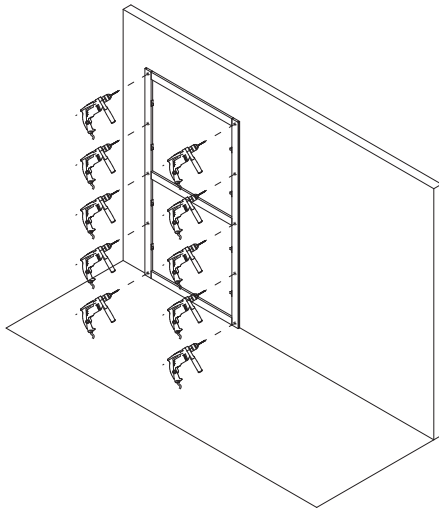

**1** Drill the frame and the wall. Insert in the wall the plugs suitable for the existent wall.

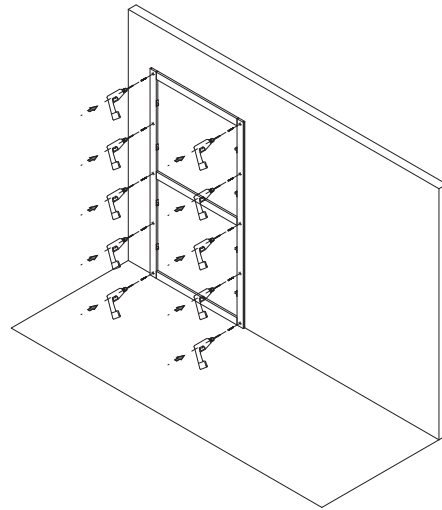

**2** Screw the frame to the wall.

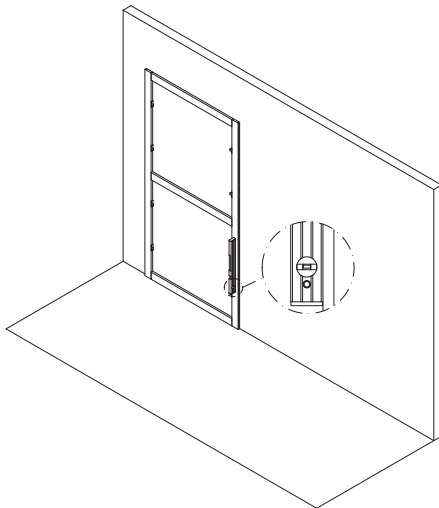

**3** Check the vertical alignment.

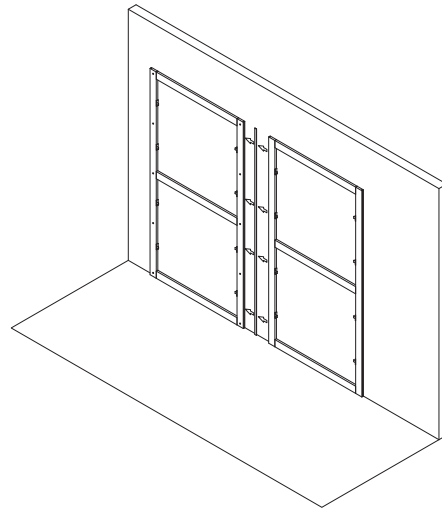

**4** Place the alignment band into the proper milling on the frame. Place the second frame mortising it, through the proper milling, with the first one, already fixed to the wall.

-Dimensions in centimeters and inches.

The right to discontinue and make changes is reserved.

This information is based on the latest product information available at the time of printing.

\_assembly instruction

wall panels

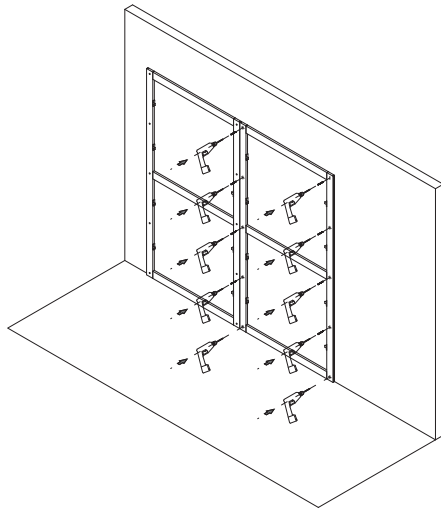

**5** Repeat the operations nr. 1 - 2 - 3 - 4 for all the frames to be installed.

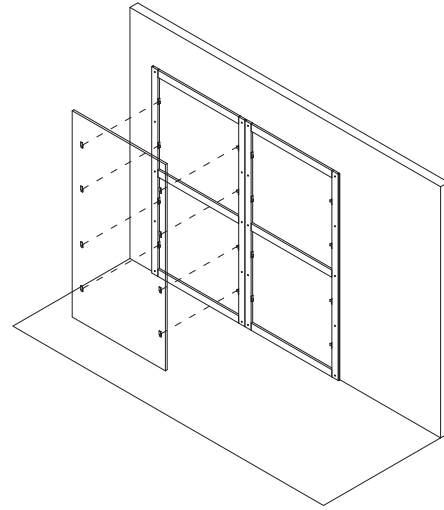

**6** Hook the wall panel through the pre-mounted frame supports and the respective ones pre-installed on the panel.

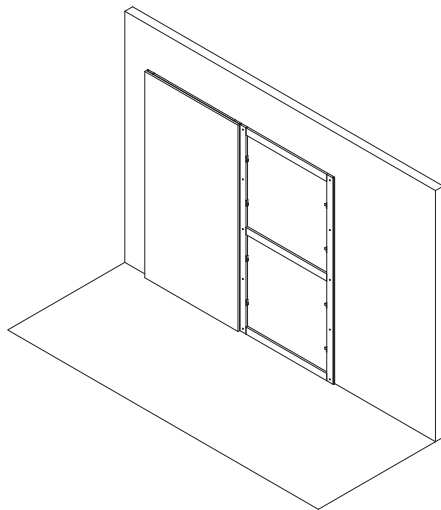

**7** Proceed with the next panels.

-Dimensions in centimeters and inches.  
The right to discontinue and make changes is reserved.  
This information is based on the latest product information available at the time of printing.

\_materials & finishes

onda carving



Maple



Oak



Teak



Canaletto Walnut



Rosewood



Wengé

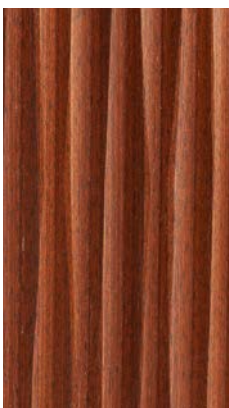

Wengé



Anilina RAL 9016



Available in all  
RAL / NCS colors



Brushed Matt Laquered



Available in all  
RAL / NCS colors

\_The finishes shown are indicative and refer to the entire production range.  
Laurameroni reserves the right to modify the range without warning.



materials & finishes

Special Finish



Warm Grey

The finishes shown are indicative and refer to the entire production range.  
Laurameroni reserves the right to modify the range without warning.

\_materials & finishes

liquid velvet



Liquid velvet  
"nocciola beige"



Liquid velvet  
"testa di moro"

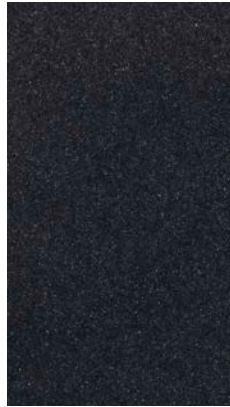

Liquid velvet  
"nero melange"



Liquid velvet  
"canna di fucile"



Liquid velvet  
"rosso borgogna"

\_The finishes shown are indicative and refer to the entire production range.  
Laurameroni reserves the right to modify the range without warning.

\_maintenance

**WOOD**

Wood is a high-quality natural product. To maintain the natural character of wood and to protect surfaces from mechanical and chemical wear, veneered surfaces are coated with a high quality transparent paint. For cleaning and care, do not use acids or alkali-based cleaners, agents with bleaching additive, scouring powder, steel wool, pot scourers or similar. Anything hot or damp will cause damage to the surface. Remove soiling and liquids immediately. Use a dry soft cloth for cleaning, eventually add a little neutral cleaning agent to the water. The cloth must be only slightly damp, to prevent discolouration or swelling of the surface. It is then essential to rub the surfaces dry, so that there is no residual moisture.

**LEGNO**

Il legno è un prodotto naturale di alta qualità. Per mantenere il carattere naturale del legno e proteggere le superfici dall'usura meccanica e chimica, le superfici impiallacciate sono rivestite con una vernice trasparente di alta qualità. Per la pulizia e la cura, non usare detergenti acidi o alcalini, agenti con additivi sbiancanti, polveri abrasive, lana d'acciaio, spugne o simili. Qualsiasi cosa calda o umida causerà danni alla superficie. Rimuovere immediatamente sporco e liquidi. Utilizzare un panno morbido e asciutto per la pulizia, eventualmente aggiungere un po' di detergente neutro nell'acqua. Il panno deve essere solo leggermente umido, per evitare scolorimenti o rigonfiamenti della superficie. È quindi essenziale strofinare gentilmente le superfici asciutte, in modo che non ci sia umidità residua.

\_maintenance

**PAINTS, LACQUERINGS AND  
SPECIAL FINISHES**

Do not use acid or alkaline detergents, agents with bleaching additives, abrasive powders, steel wool, sponges or the like. Do not use furniture polish or solvents to care for painted surfaces. Anything hot or humid can cause surface damage. Pointed or sharp objects, such as blades or knives, can cause damage to the surface. For the cleaning and care, regularly wipe the surfaces with a clean, soft, lint-free cloth to remove dust while avoiding abrasion. For soft-finish painted surfaces, use a soft, lint-free, slightly damp cloth. If heavily soiled, painted surfaces can be cleaned with a neutral, silicone-free detergent. Finally, it is essential to gently rub dry surfaces, so that there is no residual moisture.

**TINTE, LACCATURE E FINITURE  
SPECIALI**

Non usare detergenti acidi o alcalini, agenti con additivi sbiancanti, polveri abrasive, lana d'acciaio, spugne o simili. Non utilizzare lucidi per mobili o solventi per la cura delle superfici verniciate. Qualsiasi cosa calda o umida può causare danni alla superficie. Oggetti appuntiti o taglienti, come lame o coltelli, possono causare danni alla superficie.

Per la pulizia e la cura, pulire regolarmente le superfici con un panno pulito, morbido e privo di lanugine per rimuovere la polvere evitando l'abrasione. Per le superfici verniciate con finitura morbida, utilizzare un panno soffice, privo di lanugine e leggermente umido. Se molto sporche, le superfici verniciate possono essere pulite con un detergente neutro privo di silicone. È infine essenziale strofinare gentilmente le superfici asciutte, in modo che non sussista umidità residua.

**BEDIF  
FEREN  
TBEUN  
IQUE.**

LAURAMERONI s.r.l.  
22040 Alzate Brianza (Como)  
Via Manzoni, 2784  
T +39 031 761450  
info@laurameroni.com  
www.laurameroni.com